

### FEATURES

- 10-Bit Triple Video Digital-to-Analog Converter
- Output Full-Scale Voltage 0.5 to 2.0 Vp-p
- 36 MWPS Operation (typ)
- Low Power: 280 mW (1 Vp-p Output)
- 5 V Monolithic CMOS
- 52-pin QFP Package (10mm x 10mm, 0.65 mm pitch)

### APPLICATIONS

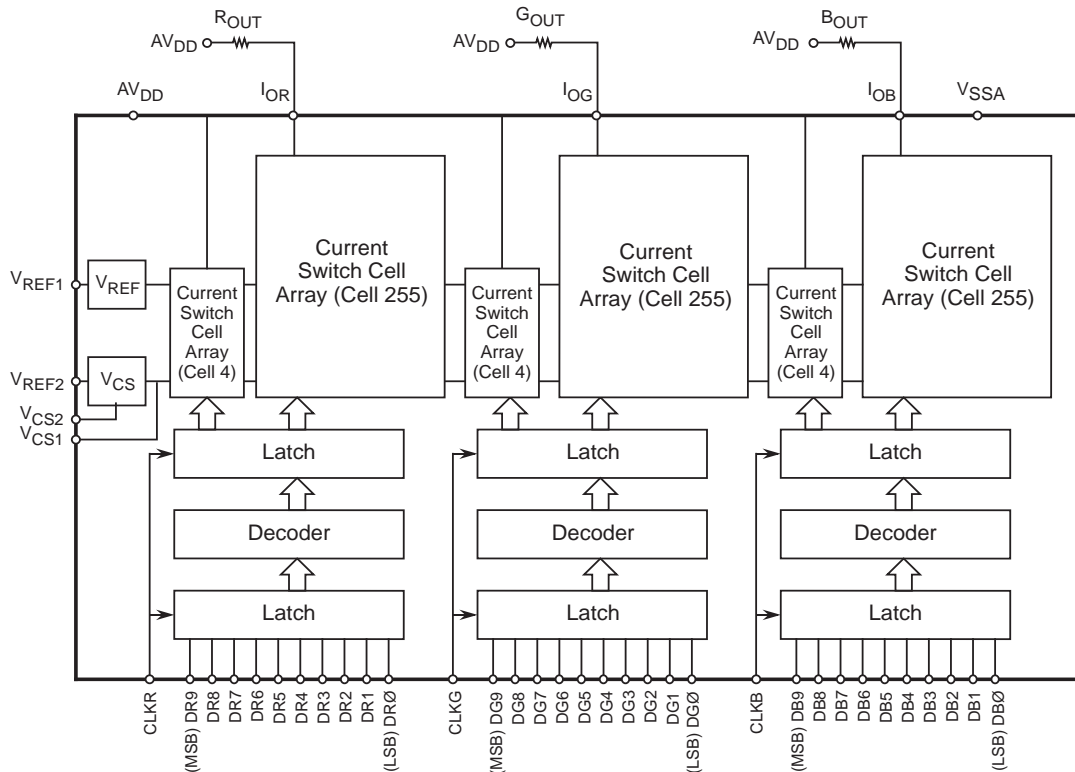
- Desktop Video Processing
- CCIR-601 Video Signal Processing
- RGB Color Monitors
- Image Processing
- Direct Digital Synthesis

### GENERAL DESCRIPTION

The SPT5230 is a 10-bit, 36 MWPS triple video digital-to-analog converter specifically designed for high performance, high resolution color graphics monitor applications and video processing applications. A single external resistor controls

the full-scale output current. The differential linearity errors of the DACs are guaranteed to be a maximum of  $\pm 1.0$  LSB over the full temperature range. The device is available in a 52-lead QFP package over the commercial temperature range.

### BLOCK DIAGRAM



**Signal Processing Technologies, Inc.**

4755 Forge Road, Colorado Springs, Colorado 80907, USA

Phone: (719) 528-2300 FAX: (719) 528-2370 Website: <http://www.spt.com> E-Mail: [sales@spt.com](mailto:sales@spt.com)

## ABSOLUTE MAXIMUM RATINGS (Beyond which damage may occur)<sup>1</sup>

### Supply Voltages

$AV_{DD}$  (measured to  $AV_{SS}$ ) ..... -0.3 to 7.0 V

### Output Current

$I_{OUT}$  ..... 0 to 14 mA

### Input Voltage

Clock and Data .....  $AV_{SS}$  to  $AV_{DD}$

### Temperature

Operating, ambient ..... 0 to +70 °C

Storage ..... -55 to +125 °C

**Note:** 1. Operation at any Absolute Maximum Rating is not implied. See Electrical Specifications for proper nominal applied conditions in typical applications.

## ELECTRICAL SPECIFICATIONS

$f_{CLK} = 27$  MWPS,  $AV_{DD} = 5.0$  V, Output Pull-Up Load = 75  $\Omega$ ,  $T_A = 25$  °C,  $AV_{SS} = 0.0$  V

PARAMETERS	TEST CONDITIONS	TEST LEVEL	MIN	TYP	MAX	UNITS
DC Performance						
Resolution				10.0		Bits
Differential Linearity	$T_A = T_{MIN}$ to $T_{MAX}$	I	-1.0		1.0	LSB
Integral Linearity		I	-2.5		2.0	LSB
Analog Outputs						
Output Voltage Range	$V_{CS2} = +2.1$ V	I	3.0		5.0	V
Conversion Rate		I	27	36		MWPS
Output Offset Voltage		I		2.4	14	mV
Signal-to-Noise Ratio		I	46	52		dB
Settling Time <sup>1</sup>		I		16	23	ns
Propagation Delay ( $t_{pd}$ )		V		10	12	ns
Crosstalk		I	-49	-54		dB
FS Control Voltage ( $V_{CS2}$ )		V	2.0		4.0	V
Digital Inputs and Timing						
Input Current, Logic High	$V_{IH} = 5$ V	I			5	$\mu$ A
Logic Low	$V_{IL} = 0$ V	I	-5			$\mu$ A
Set-Up Time, Data and Controls ( $t_s$ )		I	5			ns
Hold Time, Data and Controls ( $t_h$ )		I	10			ns
Clock Duty Cycle		V	40		60	%
Power Supply Requirements						
Supply Voltage		I	4.75		5.25	V
Supply Current	1 Vp-p Output	IV			56	mA
	2 Vp-p Output	I			100	mA
Power Dissipation	1 Vp-p Output	IV			280	mW
	2 Vp-p Output	I		485	500	mW

<sup>1</sup>Full-scale settling time to within  $\pm 2\%$  of full scale.

### TEST LEVEL CODES

All electrical characteristics are subject to the following conditions:

All parameters having min/max specifications are guaranteed. The Test Level column indicates the specific device testing actually performed during production and Quality Assurance inspection. Any blank section in the data column indicates that the specification is not tested at the specified condition.

### TEST LEVEL

I  
II  
III  
IV  
V  
VI

### TEST PROCEDURE

I 100% production tested at the specified temperature.  
 II 100% production tested at  $T_A = 25$  °C, and sample tested at the specified temperatures.  
 III QA sample tested only at the specified temperatures.  
 IV Parameter is guaranteed (but not tested) by design and characterization data.  
 V Parameter is a typical value for information purposes only.  
 VI 100% production tested at  $T_A = 25$  °C. Parameter is guaranteed over specified temperature range.

## INTERFACE CONSIDERATIONS

Figure 4 shows a typical interface circuit of the SPT5230 in normal circuit operation.

## SUPPLY AND GROUND CONSIDERATIONS

SPT suggests that all power supply pins ( $AV_{DD}$ ) be tied together and decoupled using a 0.1  $\mu\text{F}$  ceramic capacitor in parallel with a 10  $\mu\text{F}$  tantalum capacitor.

## EXTERNAL REFERENCE VOLTAGE ( $V_{REF1}$ )

A +3 V ( $\pm 10\%$ ) voltage reference should be externally generated for the  $V_{REF1}$  pin using the simple voltage divider shown in figure 4. Connect a 0.1  $\mu\text{F}$  bypass capacitor between  $V_{REF1}$  and  $AV_{SS}$  as close to the pin as possible.

## EXTERNAL REFERENCE VOLTAGE ( $V_{REF2}$ )

$V_{REF2}$  needs to be externally connected to  $AV_{DD}$  through a 1.2 k $\Omega$  (5%) resistor. Connect a 0.1  $\mu\text{F}$  bypass capacitor between  $V_{REF2}$  and  $AV_{SS}$  as close to the pin as possible.

## CONTROL VOLTAGE DECOUPLING ( $V_{CS1}$ )

This is a decoupling pin for the control voltage internal circuitry. An external 0.1  $\mu\text{F}$  capacitor should be connected between  $V_{CS1}$  and  $AV_{SS}$  as close to the pin as possible.

## FULL-SCALE ADJUST CONTROL ( $V_{CS2}$ )

$V_{CS2}$  is an external control voltage input that controls the peak-to-peak full scale output voltage. This is the only external voltage that has direct control over the SPT5230 output voltage. The voltage output swings between  $AV_{DD}$  (+5 V) and a value controlled by  $V_{CS2}$ .

Assuming that an output load resistor of 75  $\Omega$  is connected between the output and  $AV_{DD}$ , figure 2 shows what the output voltage will be for the digital inputs all equal to logic 0, as  $V_{CS2}$  is varied from 2 V to 4 V. Figure 3 shows the peak-to-peak output voltage versus  $V_{CS2}$  and table I shows an example in which  $V_{CS2}$  is equal to 2.1 V.

## CURRENT OUTPUTS

Each red, green and blue current output should have a load resistor connected to  $AV_{DD}$ . The resistors are typically 75  $\Omega$  and should be kept in the 72  $\Omega$  to 85  $\Omega$  range. The outputs should drive a high impedance load such as a voltage follower.

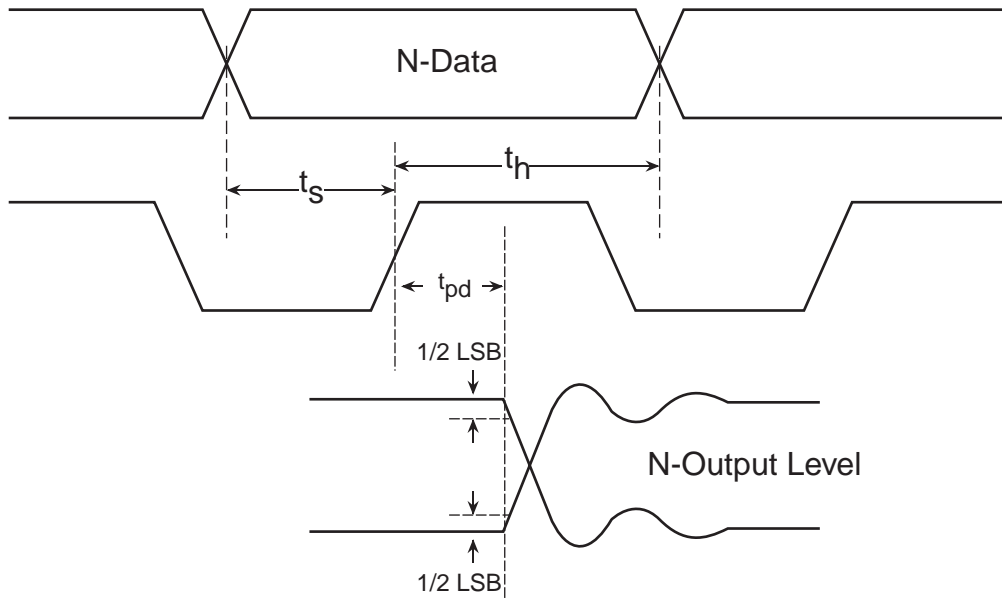
## OUTPUT LEVEL SHIFTING CIRCUIT

The SPT5230 voltage output will swing from +3.0 V to +4.99 V for  $V_{CS2} = 2.1$  V as shown in table I. If level shifting of the output is desired, SPT recommends use of the circuit shown in figure 5. The desired  $-FS$  voltage is fed into the collector of the emitter to achieve the desired level shift. (Note the phase inversion that will occur due to the common emitter.) Choose any appropriate video op amp with adequate power supply head room.

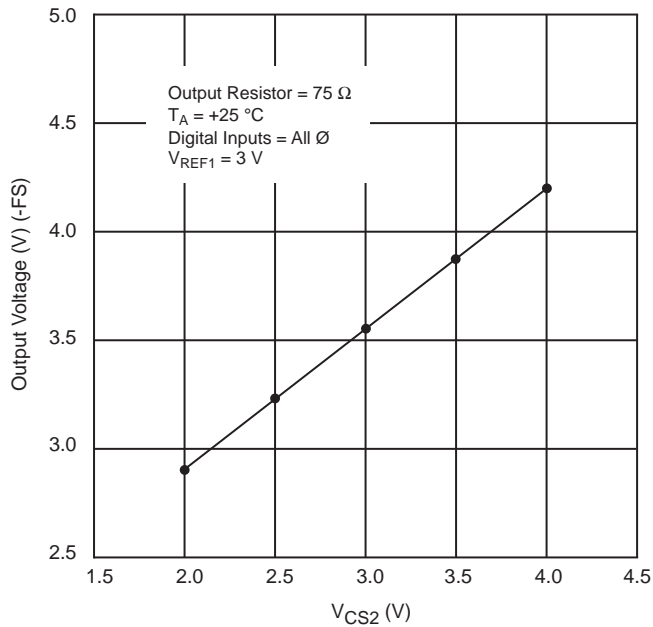
**Table I – Binary Codes**  
1 LSB = 1.953 mV,  $V_{CS2} \approx 2.1$  V

Step	Digital Input										Analog Out (V)
	A9 (MSB)	A8	A7	A6	A5	A4	A3	A2	A1	A0 (LSB)	
0	0	0	0	0	0	0	0	0	0	0	3.000000
1	0	0	0	0	0	0	0	0	0	1	3.001953
2	0	0	0	0	0	0	0	0	1	0	3.003906
3	0	0	0	0	0	0	0	0	1	1	3.005859
.				.					.		
.				.					.		
.				.					.		
1022	1	1	1	1	1	1	1	1	1	0	4.996094
1023	1	1	1	1	1	1	1	1	1	1	4.998047

**Figure 1 – Timing Diagram**

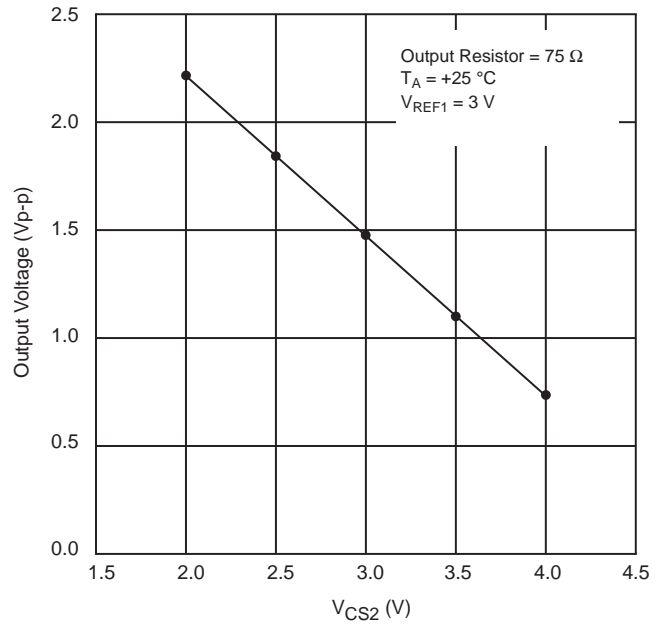


**Figure 2 – Output Voltage with All Digital Inputs = 0 versus  $V_{CS2}$**

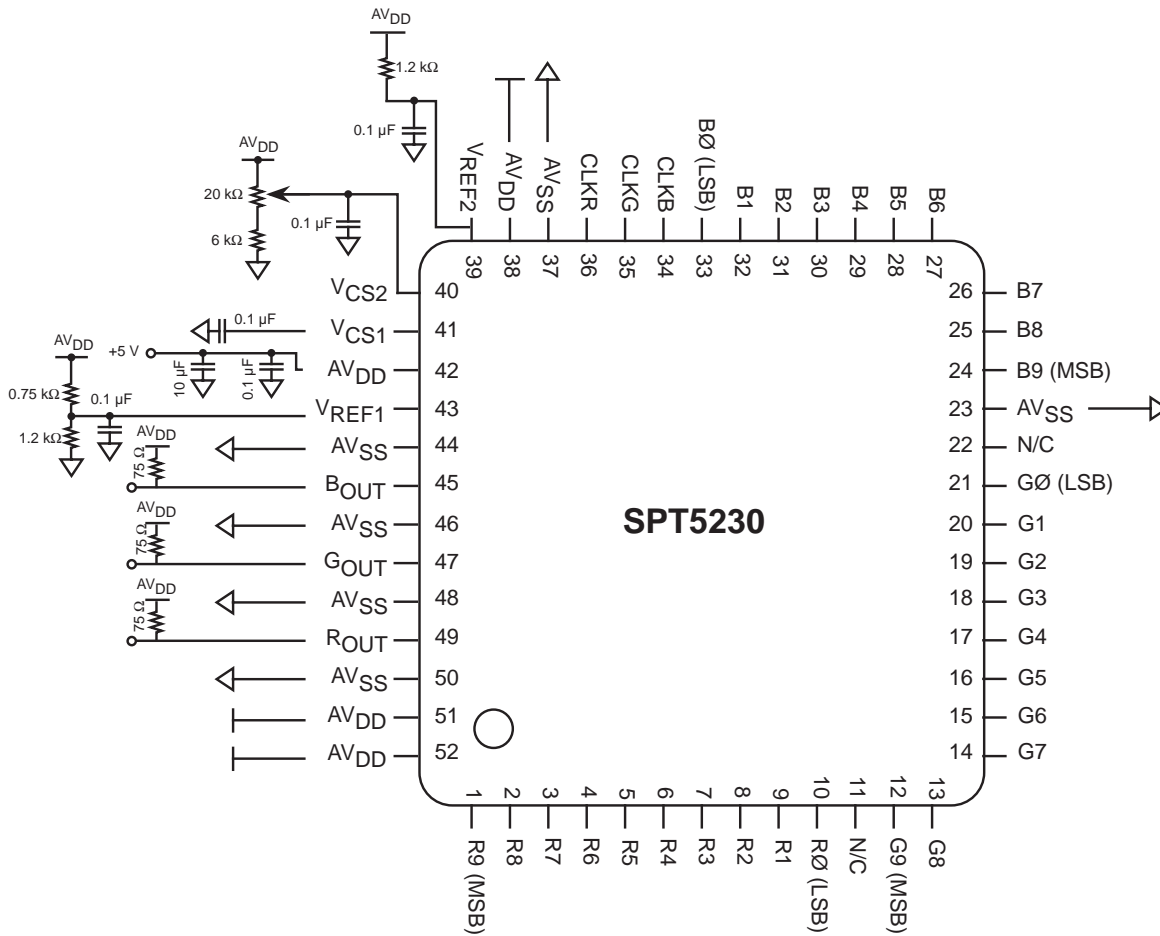


NOTE: For Digital Inputs = All 1, Output Voltage = +4.998047 V.

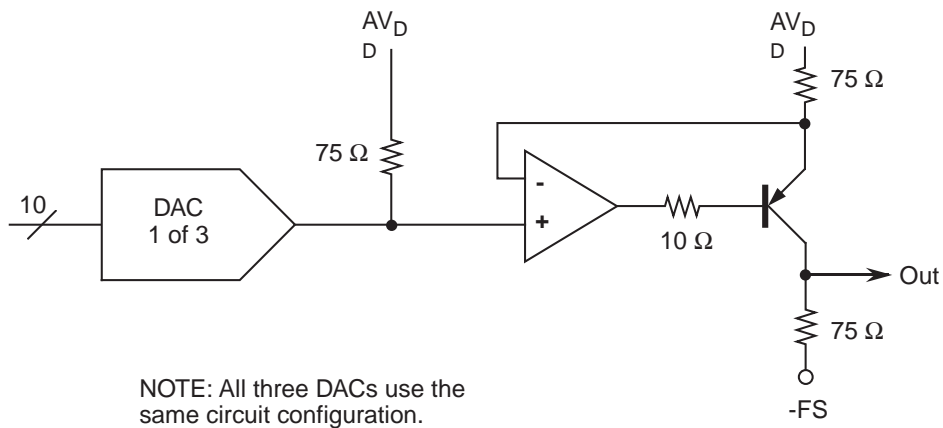
**Figure 3 – Output Voltage (Vp-p) versus  $V_{CS2}$**



**Figure 4 – Typical Interface Circuit**

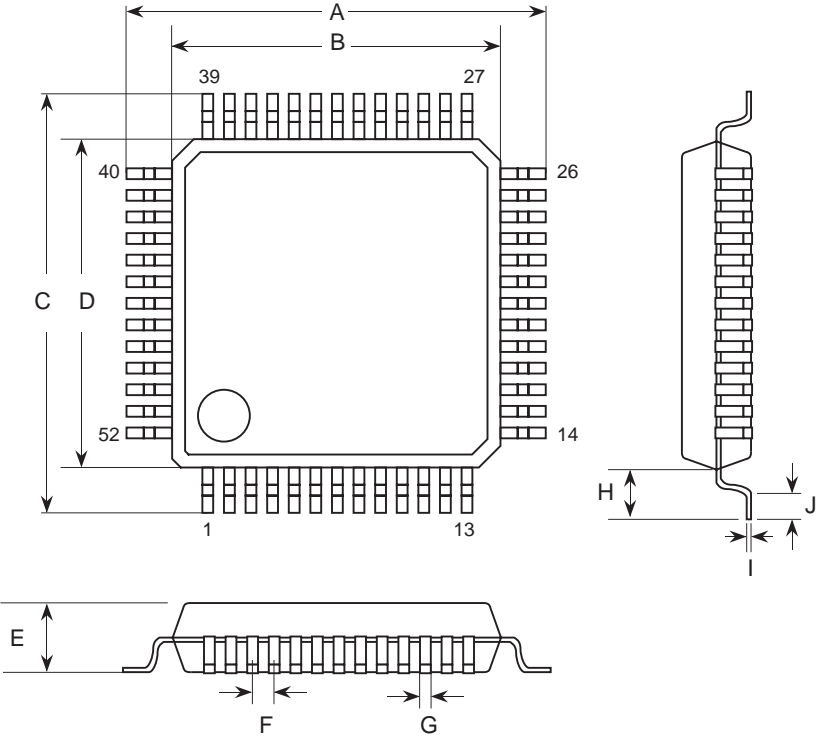


**Figure 5 – Recommended Output Level Shifting Circuit**



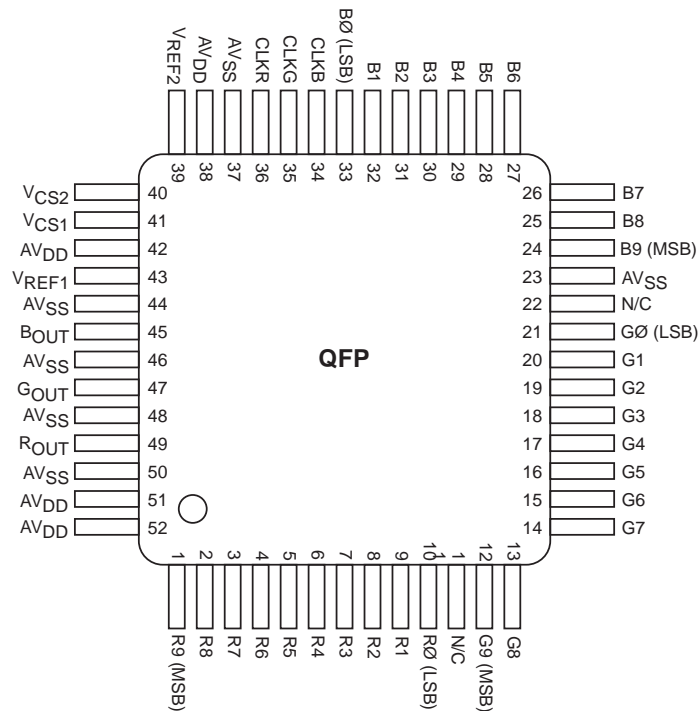
# PACKAGE OUTLINE

## 52-Lead QFP



SYMBOL	INCHES		MILLIMETERS	
	MIN	MAX	MIN	MAX
A	0.507	0.523	13.0	13.4
B	0.386	0.394	9.9	10.1
C	0.507	0.523	13.0	13.4
D	0.386	0.394	9.9	10.1
E	0.070	0.090	1.80	2.30
F	0.025 typ		0.65 typ	
G	0.008	0.016	0.2	0.4
H	0.062 typ		1.6 typ	
I	0.004	0.008	0.1	0.2
J	0.023	0.039	0.6	1.0

## PIN ASSIGNMENTS



## PIN FUNCTIONS

Name	Function
ROUT	Red Analog Current Output
GOUT	Green Analog Current Output
BOUT	Blue Analog Current Output
R0–R9	Red Data Inputs
G0–G9	Green Data Inputs
B0–B9	Blue Data Inputs
CLKR	Red Clock Input
CLKG	Green Clock Input
CLKB	Blue Clock Input
VREF1	Voltage Reference Input 1 (A 0.1 $\mu$ F ceramic capacitor should be used.)
VREF2	Voltage Reference Input 2 (A 0.1 $\mu$ F ceramic capacitor should be used.)
VCS1	Control Voltage Decoupling (A 0.1 $\mu$ F ceramic capacitor should be used.)
VCS2	Full-Scale Adjust Control Voltage (A 0.1 $\mu$ F ceramic capacitor should be used.)
AVSS	Analog Ground
AVDD	Analog Power Supply Voltage
N/C	No Connection

## ORDERING INFORMATION

PART NUMBER	TEMPERATURE RANGE	PACKAGE
SPT5230SCT	0 to +70 °C	52L QFP

Signal Processing Technologies, Inc. reserves the right to change products and specifications without notice. Permission is hereby expressly granted to copy this literature for informational purposes only. Copying this material for any other use is strictly prohibited.

**WARNING - LIFE SUPPORT APPLICATIONS POLICY -** SPT products should not be used within Life Support Systems without the specific written consent of SPT. A Life Support System is a product or system intended to support or sustain life which, if it fails, can be reasonably expected to result in significant personal injury or death.

Signal Processing Technologies believes that ultrasonic cleaning of its products may damage the wire bonding, leading to device failure. It is therefore not recommended, and exposure of a device to such a process will void the product warranty.