



DATA SHEET

SEMICONDUCTOR

KBU8A THRU KBU8M

TECHNICAL SPECIFICATIONS OF SINGLE-PHASE SILICON BRIDGE RECTIFIER

VOLTAGE RANGE-50 to 1000 Volts CURRENT-8.0 Amperes



FEATURES

- Low leakage
- Low forward voltage
- Surge overload rating: 250 Amperes peak
- High temperature soldering : 260°C / 10 seconds at terminals
- Pb free product at available : 99% Sn above meet RoHS environment substance directive request

MECHANICAL DATA

- Case: Molded plastic
- Epoxy: UL 94V-0 rate flame retardant
- Lead: MIL-STD-202E, Method 208 guaranteed
- Polarity: Symbols molded or marked on body
- Mounting position: Any
- Weight: 4.8 grams

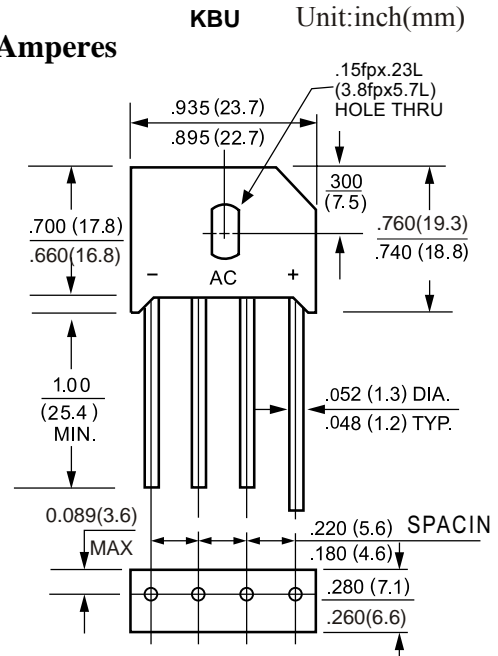

MAXIMUM RATINGS AND ELECTRICAL CHARACTERISTICS

- Ratings at 25 ambient temperature unless otherwise specified.
- Single phase, half wave, 60 Hz, resistive or inductive load.
- For capacitive load, derate current by 20%.

PARAMETER	SYMBOL	KBU8A	KBU8B	KBU8D	KBU8G	KBU8J	KBU8K	KBU8M	UNITS
Maximum Recurrent Peak Reverse Voltage	VRRM	50	100	200	400	600	800	1000	Volts
Maximum RMS Bridge Input Voltage	VRMS	35	70	140	280	420	560	700	Volts
Maximum DC Blocking Voltage	VDC	50	100	200	400	600	800	1000	Volts
Maximum Average Forward Output Current at TC = 75	IO	8.0							Amps
Peak Forward Surge Current 8.3 ms single half sine-wave superimposed on rated load	IFSM	250							Amps
Maximum Forward Voltage Drop per element at 8.0A DC	VF	1.0							Volts
Maximum DC Reverse Current at Rated DC Blocking Voltage per element	@TA = 25	5							μAmp
	@TA = 100	500							
I2t Rating for Fusing(t<8.3ms)	I2t	127							A2Sec
Typical Junction Capacitance(Note1)	CJ	186							pF
Typical Thermal Resistance(Note2)	R JA	10							/W
Operating Temperature Range	TJ ,TSTG	-55 to + 150							

NOTES: 1. Measured at 1 MHz and applied reverse voltage of 4.0 volts

2. Thermal Resistance from Junction to Ambient and from junction to lead mounted on P.C.B with 0.47x0.47"(12x12mm) copper plate.

DEVICE CHARACTERISTICS

KBU8A THRU KBU8M

FIG. 1 - MAXIMUM NON-REPETITIVE FORWARD SURGE CURRENT

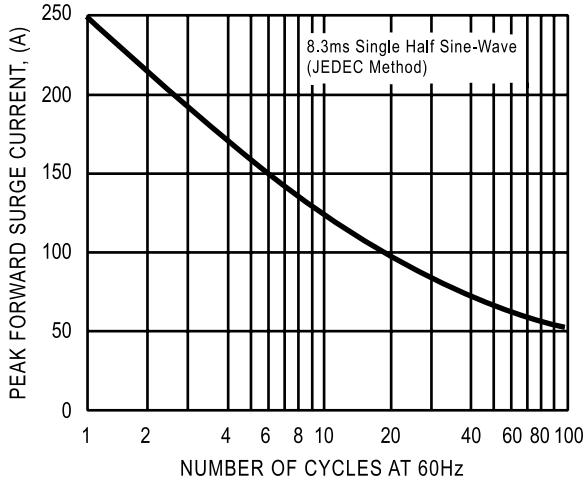

FIG. 2 - TYPICAL FORWARD CURRENT DERATING CURVE

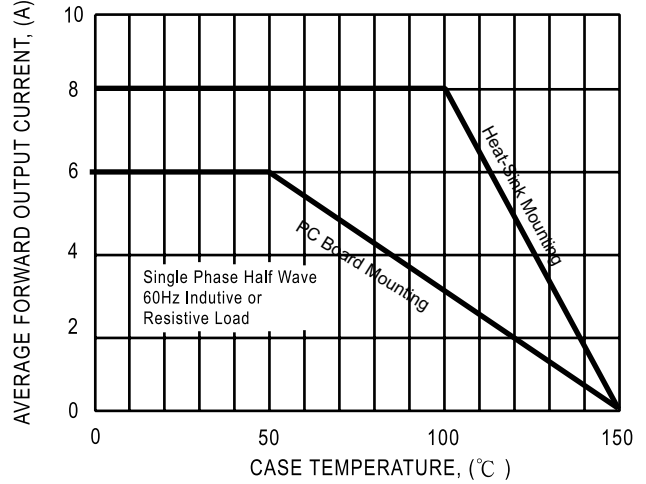

FIG. 3- TYPICAL INSTANTANEOUS FORWARD CHARACTERISTICS

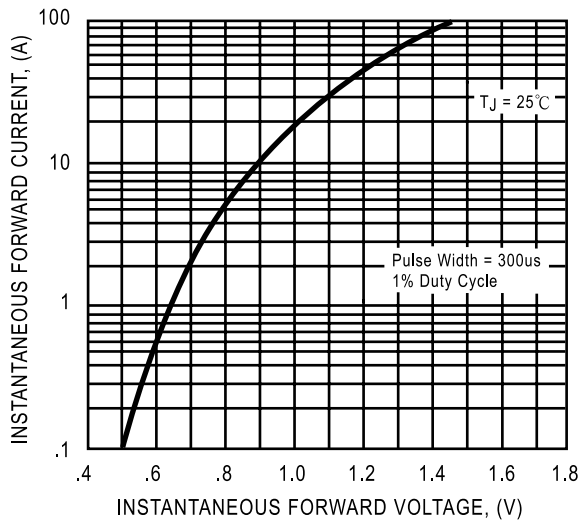

FIG. 4 - TYPICAL REVERSE CHARACTERISTICS

